

# SSI 674 / 675 / 684 / 685



## Absolute single and multiturn encoders

- ▶ 13 or 25 bit with synchro-, clamping- or stator flange
- ▶ IP 66 at housing, IP 64 at shaft inlet
- ▶ 58 mm diameter
- ▶ 10...30 Vdc
- ▶ Available with 6 or 10 mm stub-shaft or 12 mm hollow-shaft



674/684

675/685

674/684 Hollow shaft

## ELECTRICAL SPECIFICATION

Supply voltage +EV	10-30V
	Polarity protected
Current consumption at no load	190mA @ 24V Max 250mA
Resolution	
Singleturn	13 bit, 8192 positions / revolution
Multiturn	12 bit, 4096 distinguishable revolutions
Accuracy	$\pm \frac{1}{2}$ LSB
Incremental track	Sinusoidal 1Vpp
Resolution	512 $\pm$ 60"
Outputs, Serial	SSI
Code	Gray
CLOCK input	RS-485
DATA output	RS-485
Frequency range CLOCK	100kHz - 1MHz
Cable length	Max 100m

## ACCESSORIES

Mating connector	Part. No. 01209085
Mounting bracket	See datasheets for accessories
Mounting kit	
Bearing box	
Couplings	

## DESCRIPTION SSI

Simple and fast serial point-to-point communication. The absolute positional value (DATA) is sent synchronously with a CLOCK signal from the receiver electronics.

The length of the data word is 13 bits for a singleturn encoder and 25 bits for a multiturn encoder.

When no communication takes place with the encoder, CLOCK and DATA have a high level. The positional value is saved on the first falling edge of the CLOCK signal. The saved positional value is clocked out on the subsequent rising edges with the most significant bit first.

After sending a complete data word, DATA will maintain a low level for 12-35  $\mu$ s, and when the DATA signal again receives a high output signal the encoder is ready to send a new positional value. If a new falling edge is received from CLOCK before the DATA signal has given a high output signal, the same positional value will be sent once more.

## CONNECTION

Function	17 pin EML
Sensor +E Volt	1
Sensor 0 Volt	4
+E Volt	7
0 Volt	10
Clock	8
Clock	9
Data	14
Data	17
Internal screen	11
<u>1</u>	12
1	13
<u>2</u>	15
2	16

# 674/675/684/685 SSI

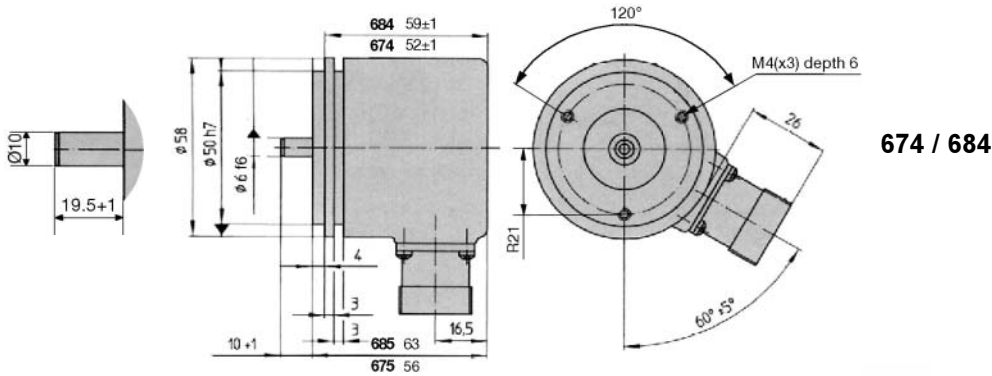

674 / 684 Hollow shaft

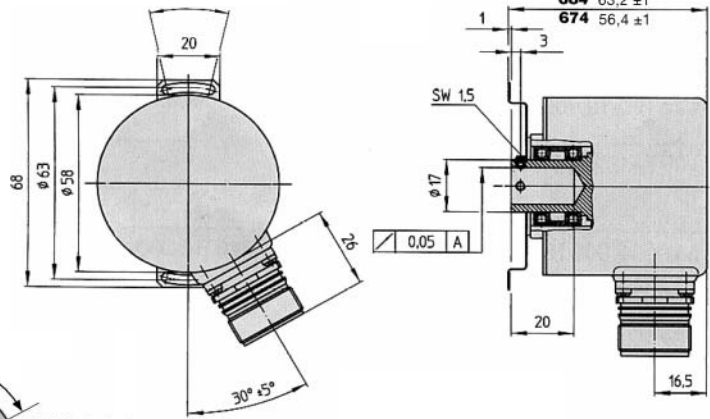

675 / 685

## MECHANICAL SPECIFICATION

Shaft, Stainless steel	Stub-shaft Ø 6, 10mm	Hollow-shaft Ø 12 mm
Moment of inertia	3,8 x 10 <sup>-6</sup> kgm <sup>2</sup>	4,6 x 10 <sup>-6</sup> kgm <sup>2</sup>
Load max		
Radial	60N	20N
Axial	40N	10N
Speed max	6000 rpm	
Code disc	Glass disc	
Temperature		
Operating	-20°C ... +100°C	
Storage	-30°C ... +80°C	
Housing	Aluminium	
Weight	Approx. 300g	
Protection class	IP 66 according to IEC 529	
Shaft inlet	IP 64 according to IEC 529	
Vibration	<100m/s <sup>2</sup> (50...2000 Hz)	
Shock	<1000m/s <sup>2</sup> (11ms)	
Connection	17-pin radial EML	

## ORDERING INFORMATION

### Available models

- 674 202251**  
13 Bit singleturn with 6mm stub-shaft and synchro flange
- 674 205251**  
13 Bit singleturn with 12mm hollow-shaft and stator coupling
- 675 204251**  
13 Bit singleturn with 10mm stub-shaft and clamping flange
- 684 202251**  
25 Bit multiturn with 6mm stub-shaft and synchro flange
- 684 205251**  
25 Bit multiturn with 12mm hollow-shaft and stator coupling
- 685 204251**  
25 Bit multiturn with 10mm stub-shaft and clamping flange

**Leine&Linde** ISO 9001 certified

Leine&Linde AB, Box 8, SE-645 21 Strängnäs, Sweden. Olivehällsvägen 8.  
Phone: +46 (0)152 265 00. Fax: +46 (0)152 265 05. E-mail: info@leinelinde.se

02-04-09 PS. Specifications can be changed without prior notice.